



SF₆ FREE
www.greenswitching.com

STROM • SICHER • SCHALTEN

DRIESCHER
Medium voltage switchgear
PRO-AIR H

- Indoor
- Air-insulated
- Rated voltage 36 kV

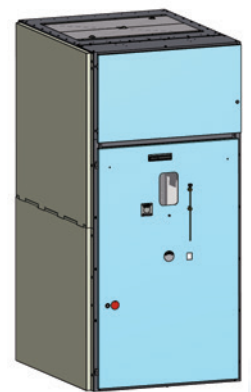

DRIESCHER
Moosburg • Eisleben



Contents

3	Short description, General description
4	General description PRO-AIR H
5	Equipment and setup
6	PRO-AIR H•a•, Technical data, Types
7	PRO-AIR H•a•, Types
8	PRO-AIR H•c•, Technical data, Types
9	PRO-AIR H•c•, Types
10	PRO-AIR H•c•L, Type Circuit breaker panel (semi-fixed type) I_k 20 kA
11	PRO-AIR H•e•, Technical data, Types
12	PRO-AIR H•e•, Types
13	PRO-AIR H•e•L, Type Circuit breaker panel (semi-fixed type) I_k 20 kA
14	PRO-AIR H•e•EL, Type Circuit breaker panel in withdrawable unit design I_k 20 kA
15	PRO-AIR H•e•EL, Type Circuit breaker panel in withdrawable unit design I_k 31,5 kA

DRIESCHER

STROM • SICHER • SCHALTEN

PRO-AIR H - Your advantages

- *Easy access*
- *Simple operation*
- *Air-insulated, SF6-free*
- *Optimal environmental compatibility*
- *Minimal maintenance requirements*
- *Maximum safety and reliability*
- *Modular design, can be extended and expanded*

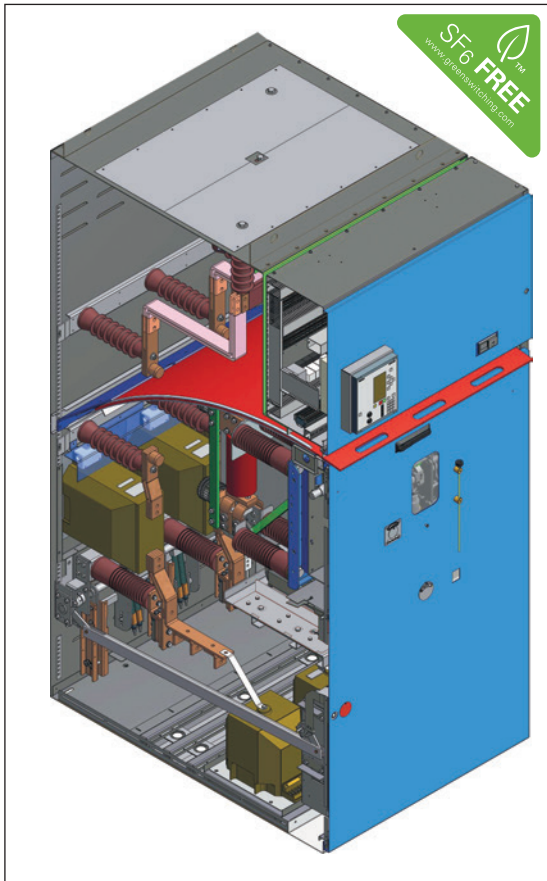

Fig. 1: Exemplified: PRO-AIR H•e•EL, I_k 31,5 kA

Short description

- Type-tested acc. to EN 62271-200
- Rated voltage 36 kV
- Rated current up to 2000 A
- Rated short-time current up to 31,5 kA, 3s
- Degree of protection IP3X
- Loss of service continuity LSC2, PI
- Internal arc classification IAC A FL(R) 31,5 kA 1s

Type description example

PRO-AIR
H•e•EL

- Type panel*: Circuit breaker panel-in withdrawable unit design
- Size a 900 wide/1200 deep/2100 high
- Size c 900 wide/1200 deep/2600 high
- Size e 1200 wide/1500 deep/2600 high
- Rated voltage 36 kV

General description

The metal-glad, air-insulated medium-voltage switchgear from the PRO-AIR H panel range is used specifically when an extremely high supply reliability must be guaranteed and a high level of personal safety and operating comfort are essential. This switchgear fulfils the specific requirements of the user in all respects.

The PRO-AIR H is delivered as individual panels, which can be equipped with earthing switches, motor drives, current and voltage transformers etc. individually according to the customer specifications.

The PRO-AIR H switchgear is available in the following sizes and types:

Switchgear sizes	Dimensions Width x Depth x Height in mm	Rated short-time current I_k up to	Available Types*
PRO-AIR H•a	900 x 1200 x 2100	20 kA	K, T, Ü, H, M
PRO-AIR H•c	900 x 1200 x 2600	20 kA	K, T, Ü, H, M, L
PRO-AIR H•e	1200 x 1500 x 2600	31,5 kA	K, T, Ü, H, M, L, EL

*Types: K=Cable panel, T=Transformer feeder panel, Ü=Bus sectionalizer panel, H=Riser panel, M=Measuring panel, L=Circuit breaker panel (semi-fixed type), EL=Circuit breaker panel in withdrawable unit design

Technical standards

The metal-clad, air-insulated PRO-AIR H panels are type-tested in accordance with EN 62271-200. The switchgear and the switching devices comply with the following standards:

	High-voltage switchgear and switches -
EN 62271-1	Teil 1: Common specifications
EN 62271-200	Teil 200: AC metal-enclosed switchgear and controlgear for rated voltages above 1 kV and up to and including 52 kV
EN 62271-100	Teil 100: Alternating current circuit breakers
EN 62271-102	Teil 102: Alternating current disconnectors and earthing switches
EN 62271-103	Teil 103: Switches for rated voltages above 1 kV up to and including 52 kV
EN 62271-105	Teil 105: Alternating current switch-fuse combinations for rated voltages above 1 kV up to and including 52 kV

Operating conditions

The PRO-AIR H panels are installed in closed electrical operating facilities, which may only be accessed by specialist personnel and instructed persons (accessibility level A). They can be used up to an installation altitude of 1000 m above sea level.

For installation altitudes above 1000 m, the rated insulation level of the switchgear must be corrected accordingly. The panels are designed for use under normal operating conditions in accordance with EN 62271-1.

Installation

When installing the PRO-AIR medium-voltage switchgear, the following minimum installation room height must be observed:

Switchgear sizes	Minimum - Room height Rh	Minimum - Room height with pressure relief duct Rh
PRO-AIR H•a	2400 mm	2450 mm
PRO-AIR H•c	3000 mm	3000 mm
PRO-AIR H•e	3000 mm	3000 mm

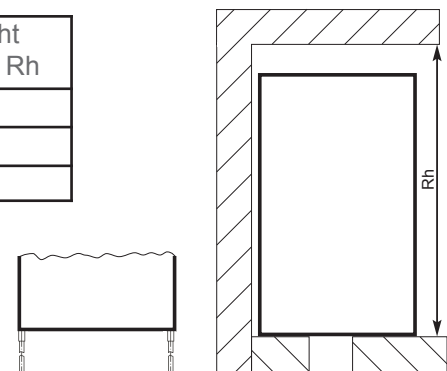

Fig. 2: PRO-AIR installation side view left side on access floor, right side on concrete floor

Switching devices

The following switching devices are used in the different versions of PRO-AIR H:

- Switch-disconnector H22 EK / EA
- Switch-disconnector H29 EA
- Disconnector ITr 36-630-20, ITr 36-1600-20
- Vacuum circuit breaker V36-630-20 KUF, V36-1250-20 KUF, V36-2500-31,5 KUF
- Switch-fuse combination H22 SEA
- Switch-fuse combination H29 SEA
- Earthing switch ES 36-20, ES 36-31,5



Equipment and setup

The panel structure is made of a screwed, hot-dip galvanised composite structure. On the front of the panels, there is a single-leaf steel sheet door. The door hinge can be on the right or left as desired. A inspection window made from laminated safety glass is installed in this door.

The plate in front of the busbar compartment is optionally designed as the door for the secondary cabinet behind it. It has the following dimensions WxDxH: 900/1200mm x 230/470mm x 690/900 mm (raised 900mm) and can be fitted with one or several protective relays according to customer specifications.

The corrosion protection of the doors and plates and the side walls of the switchgear is guaranteed with textured paint (colour RAL - according to customer specifications).

The side partitioning of the busbar compartment from the neighbouring panel is achieved using glass fibre reinforced plastic sheets with feedthroughs. Each panel has a screwed-on rear wall made from galvanized sheet metal.

The pressure relief takes place to the bottom and top. Cables to be connected are fed into the panels from below and placed on adjustable crossbars.

All panels have a central lock with double bit key. Locking options with profile cylinders or padlocks are also available on request.

The installed switching devices can be actuated manually or via motor drive when the panel door is closed. The optional interlocking between the switching devices helps to prevent operating errors.

Earthing switches or fixed ball points are available for earthing and short-circuiting. Where necessary, suitable surge voltage protectors can be installed in the panel.

An insulating protective barrier (in accordance with DIN VDE 0682, Part 552) can be pushed in when the panel door is closed. This insulating protective barrier is designed to prevent a prohibited approach or accidental contact with live components. It should be pushed in if work is to be carried out in the panel and the system can not be completely de-energised.

Mounting on existing switchgear is possible and the previous switchgear model W36 can also be upgraded.



PRO-AIR H - Additional equipment

- *Panel lighting*
- *Busbar earthing with fixed ball points*
- *Capacitive voltage detection system*
- *Surge voltage protector (SVP)*
- *Short-circuit indicator*
- *Base plates*
- *Additional locking options with profil cylinders and lockable operating mechanism*
- *Mechanical and electrical Interlockings*
- *Remote control system*



PRO-AIR H•a

The H•a version is available as a cable panel, transformer feeder panel, bus sectionalizer panel, riser panel and measuring panel up to I_k 20 kA. The PRO-AIR H•a-K weighs approximately 450 kg in the standard version.

PRO-AIR H•a		
• Rated voltage	U_r	36 kV
• Rated frequency	f_r	50 Hz
• Rated operating current, max.	I_r	630 A
• Rated short-time current, max.	I_k	20 kA
• Rated short-circuit time	t_k	3 s
• Rated peak withstand current	I_p	50 kA
• Rated lightning impulse withstand voltage	U_p	170 kV
• Rated power-frequency withstand voltage	U_d	70 kV

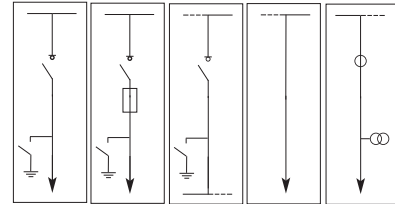

PRO-AIR H•a - Types cable-, transformer feeder-, bus sectionalizer-, riser-, measuring panel.

Switchgear design

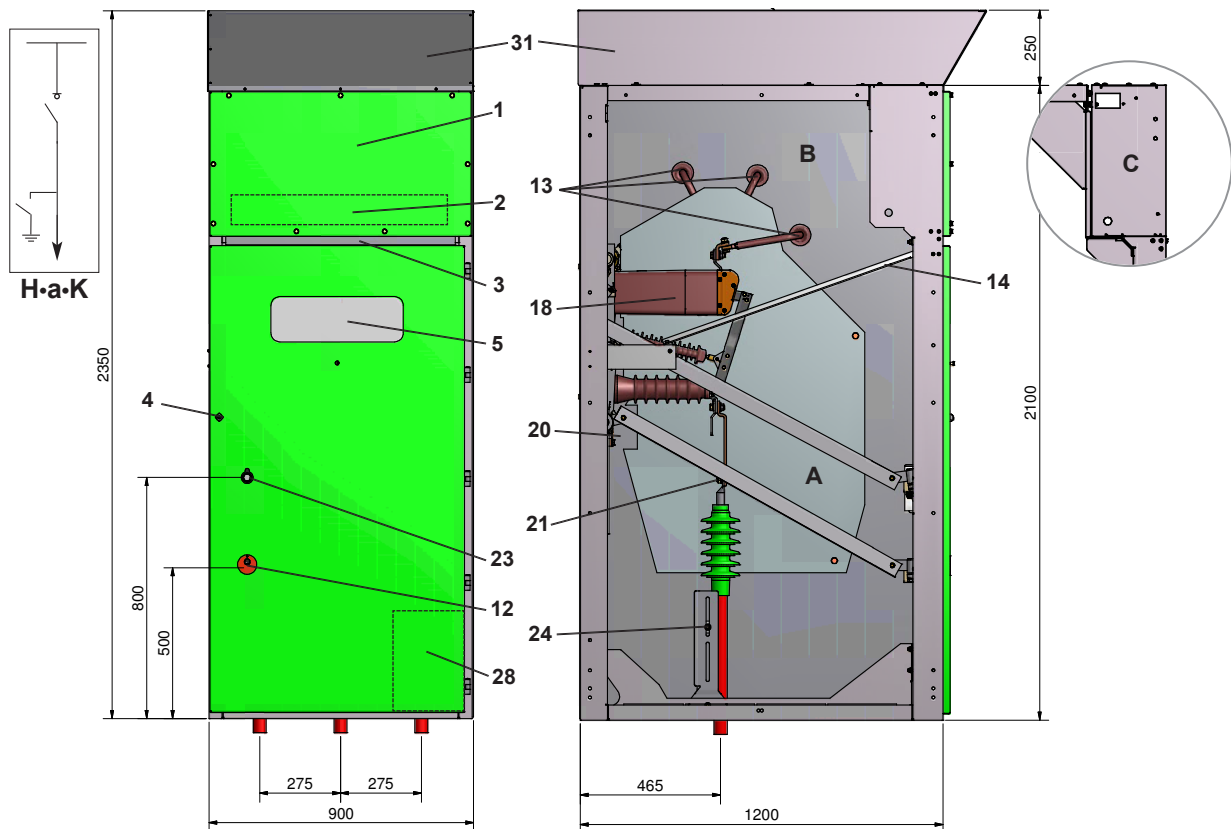

Fig. 3: PRO-AIR H•a-K, Type cable panel, right side secondary cabinet

- | | | |
|--|--|--|
| 1 Door or plate secondary cabinet | 13 Busbar | 28 Wiring cabinet ² |
| 2 Area for voltage detection system ²
Short-circuit indicator ² | 14 Insulating protective barrier | 31 Arc rejection device |
| 3 Opening for insulating protective barrier | 18 Switch-disconnector H29 | A Cable connection- and switch-
gear area |
| 4 Door central lock | 20 Earthing switch | B Busbar area |
| 5 Inspection window | 21 Cable connection | C Secondary cabinet ¹ |
| 12 Operation and Position indication ES ¹ | 23 Operation and Position indication SD ¹ | |
| | 24 Crossbar, adjustable | |

¹ SD=Switch-disconnector H29, ES=Earthing switch, ² as option

Switchgear design

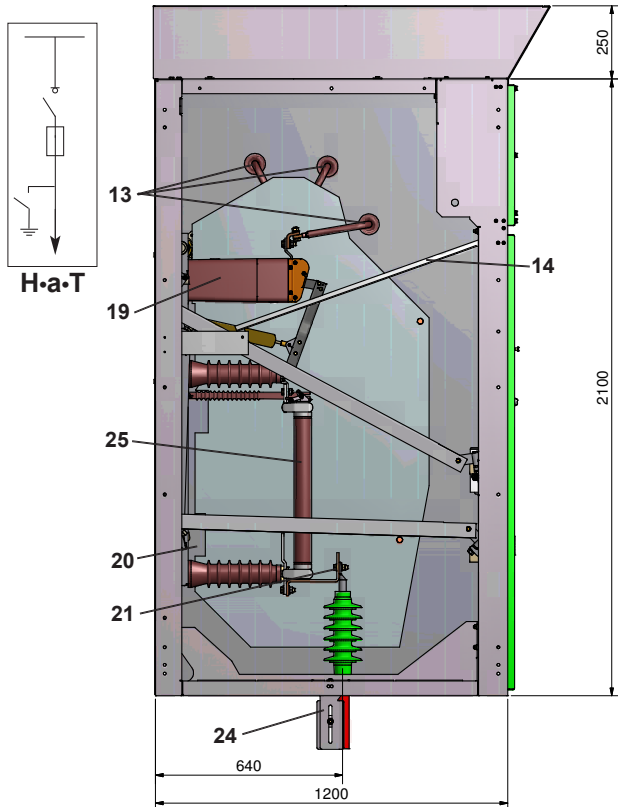

Fig. 4: PRO-AIR H-a-T, Type transformer feeder panel

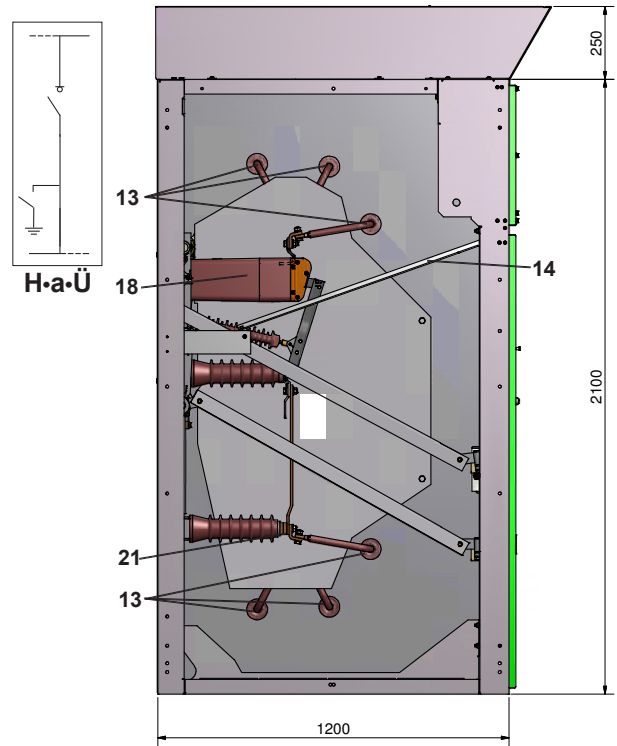

Fig. 5: PRO-AIR H-a-U, Type bus sectionalizer panel

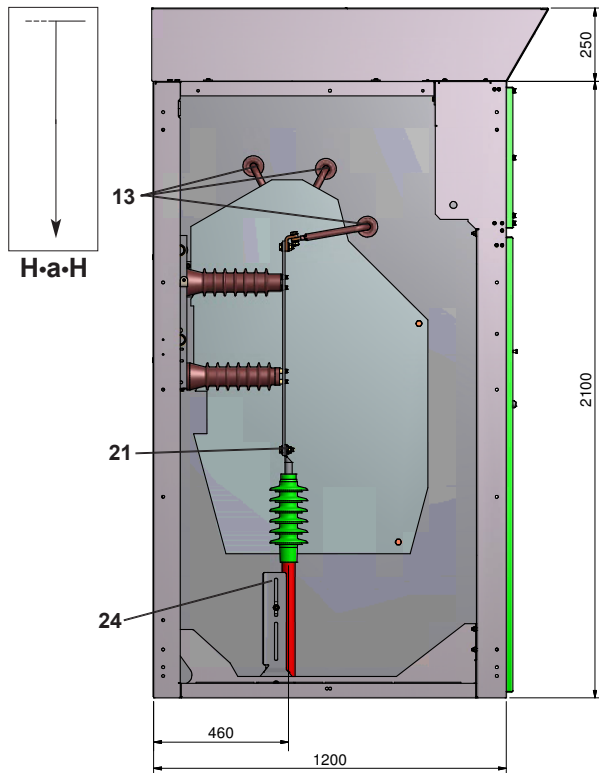

Fig. 6: PRO-AIR H-a-H, Type riser panel

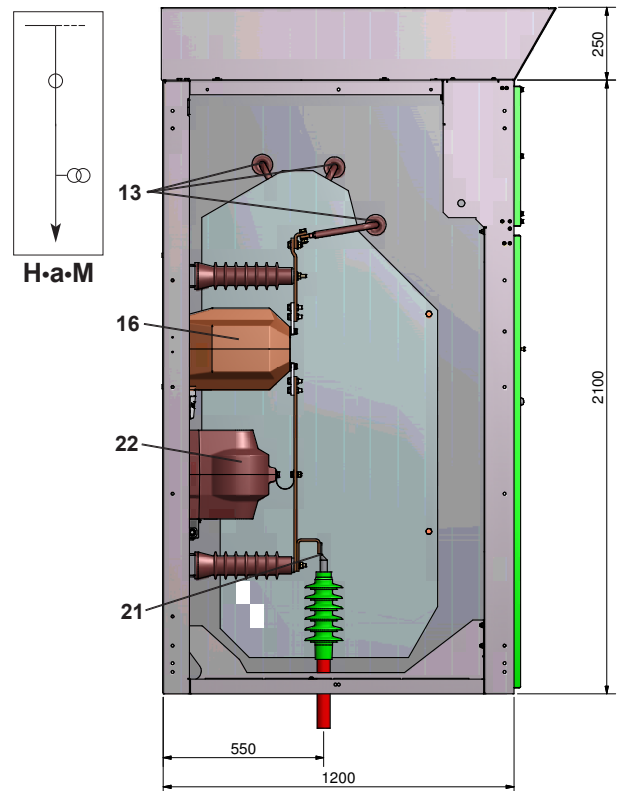

Fig. 7: PRO-AIR H-a-M, Type measuring panel

13 Busbar 14 Insulating protective barrier 16 Current transformer 18 Switch-disconnector H29 19 Switch-fuse combination H29
 20 Earthing switch 21 Cable connection 22 Voltage transformer 24 Crossbar, adjustable 25 H.v.h.b.c fuses

PRO-AIR H•c

The H•c version is available as a cable panel, transformer feeder panel, bus sectionalizer panel, riser panel, measuring panel and circuit breaker panel (semi-fixed type) up to I_k 20 kA. The PRO-AIR H•c•K weighs approximately 560 kg in the standard version.

PRO-AIR H•c		
• Rated voltage	U_r	36 kV
• Rated frequency	f_r	50 Hz
• Rated operating current, max.	I_r	630 A
• Rated short-time current, max.	I_k	20 kA
• Rated short-circuit time	t_k	3 s
• Rated peak withstand current	I_p	50 kA
• Rated lightning impulse withstand voltage	U_p	170 kV
• Rated power-frequency withstand voltage	U_d	70 kV

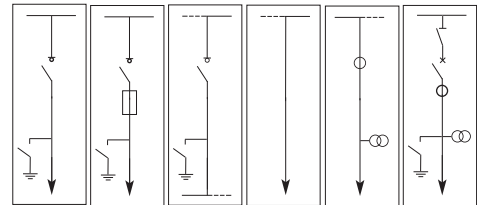

PRO-AIR H•c - Types cable-, transformer feeder-, bus sectionalizer-, riser-, measuring- and circuit breaker panel (semi-fixed type)

Switchgear design

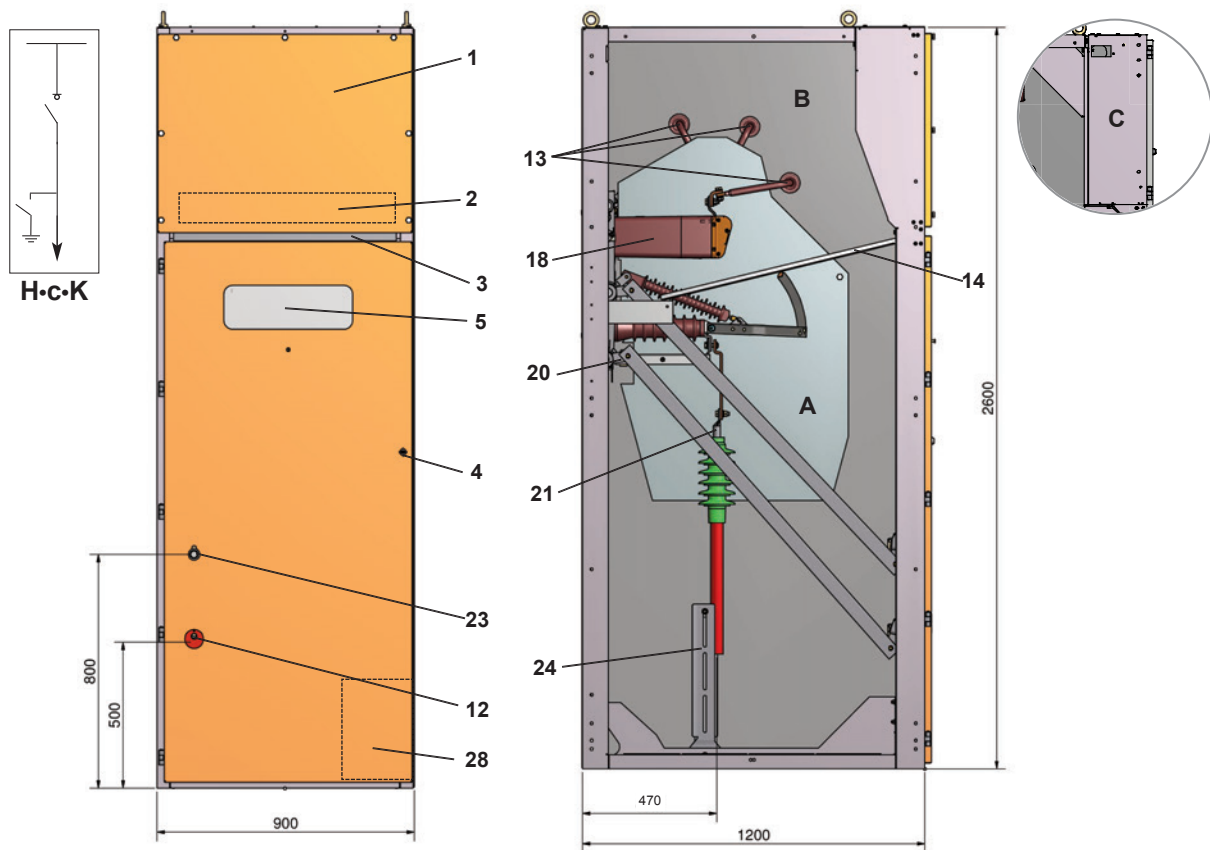

Fig. 8: PRO-AIR H•c•K, Type cable panel, right side secondary cabinet

- | | | |
|---|--|--|
| 1 Door or plate secondary cabinet | 13 Busbar | 28 Wiring cabinet ² |
| 2 Area for voltage detection system ² . Short-circuit indicator ² | 14 Insulating protective barrier | A Cable connection- and switch-gear area |
| 3 Opening for insulating protective barrier | 18 Switch-disconnector H29 | B Busbar area |
| 4 Door lock | 20 Earthing switch | C Secondary cabinet ¹ |
| 5 Inspection window | 21 Cable connection | |
| 12 Operation and Position indication ES ¹ | 23 Operation and Position indication SD ¹ | |
| | 24 Crossbar, adjustable | |

¹ SD=Switch-disconnector H29, ES=Earthing switch, ² as option

Switchgear design

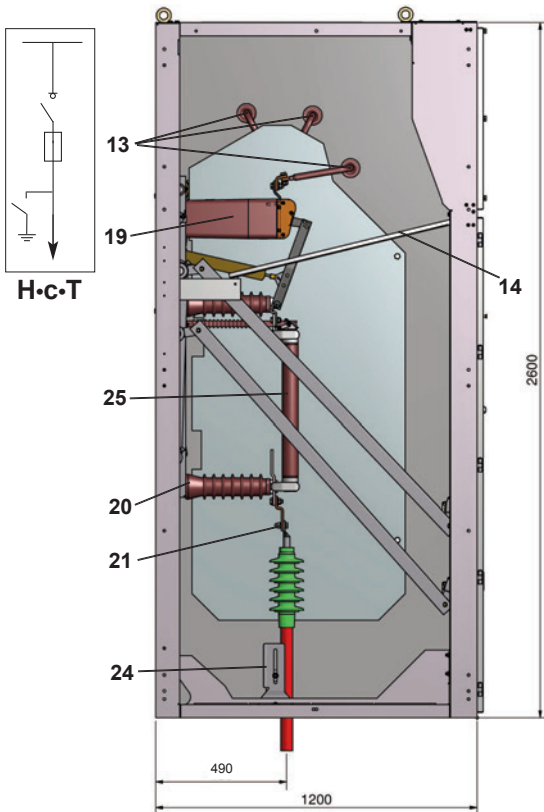

Fig. 9: PRO-AIR H-c-T, Type transformer feeder panel

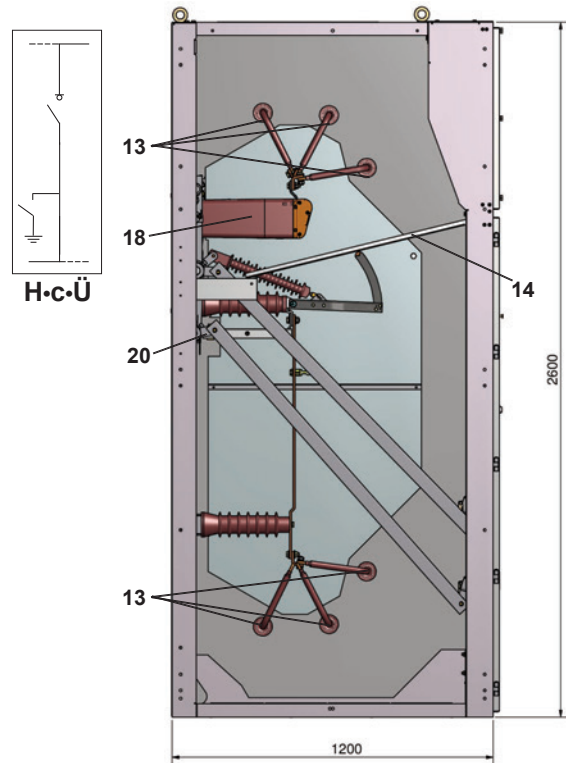

Fig. 10: PRO-AIR H-c-Ü, Type bus sectionalizer panel

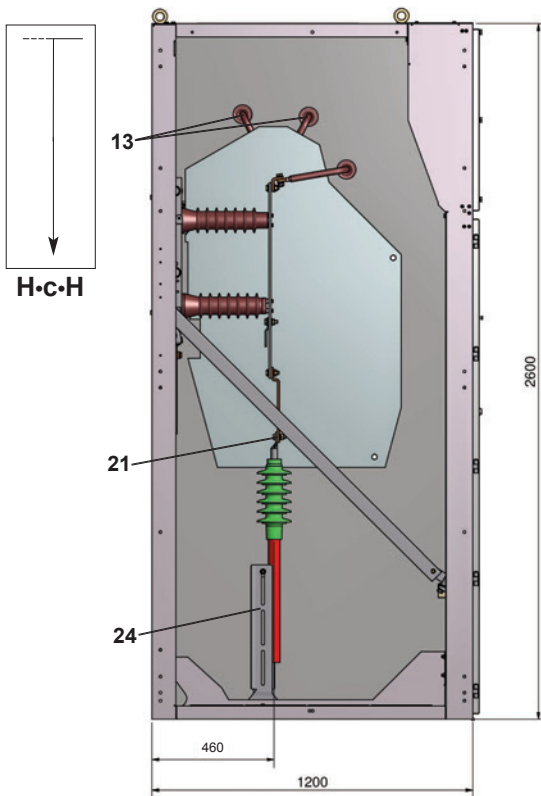

Fig. 11: PRO-AIR H-c-H, Type riser panel

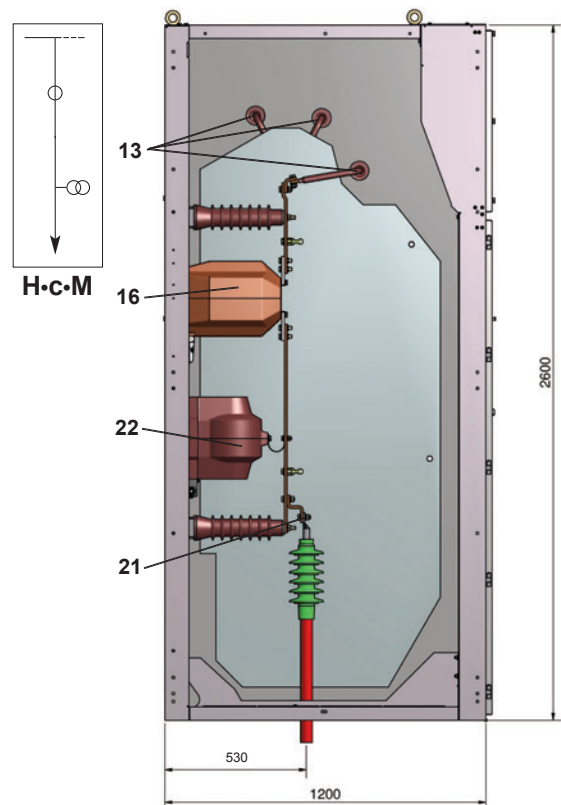

Fig. 12: PRO-AIR H-c-M, Type measuring panel

- 13 Busbar 14 Insulating protective barrier 16 Current transformer 18 Switch-disconnector H29 19 Switch-fuse combination H29
- 20 Earthing switch 21 Cable connection 22 Voltage transformer 24 Crossbar, adjustable 25 H.v.h.b.c fuses



Switchgear design

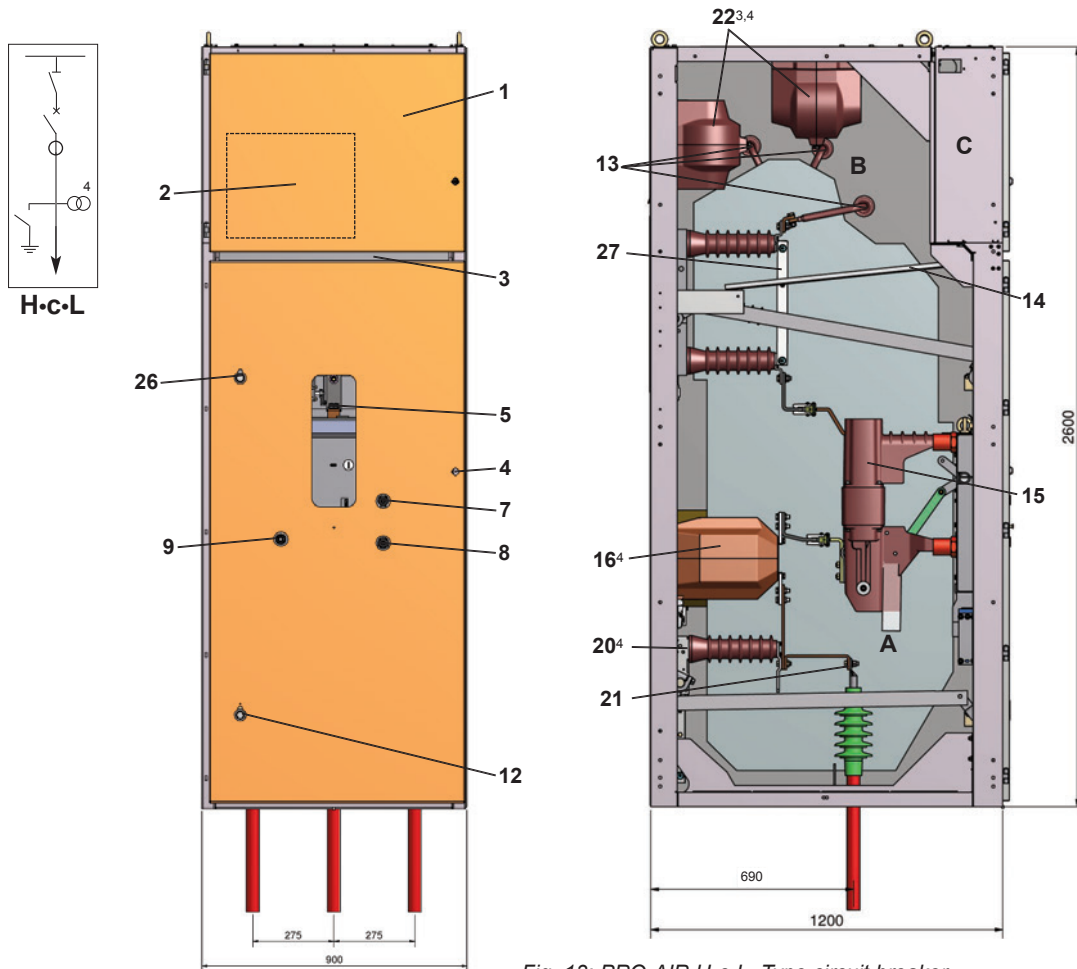

Fig. 13: PRO-AIR H•c•L, Type circuit breaker panel (semi-fixed type)

- | | | |
|--|--|--|
| 1 Door secondary cabinet | 12 Operation and Position indication ES ¹ | 26 Operation and Position indication DI ¹ |
| 2 Area for Protective relay ² , Operation-elements ² , Voltage detection system ² | 13 Busbar | 27 Disconnecter |
| 3 Opening for insulating protective barrier | 14 Insulating protective barrier | 30 Service truck ² , see fig. 20 |
| 4 Door central lock | 15 Vacuum circuit breaker | |
| 5 Inspection window for indication VCB ¹ | 16 Current transformer ⁴ | |
| 7 Manual operation VCB ¹ ON | 20 Earthing switch ⁴ | |
| 8 Manual operation VCB ¹ OFF | 21 Cable connection | A Cable connection- and switch-gear area |
| 9 Hand-wound mechanism VCB ¹ | 22 Voltage transformer ^{3,4} | B Busbar area |
| | 24 Crossbar, adjustable | C Secondary cabinet |

¹ VCB=Vacuum circuit breaker, DI=Disconnecter, ES=Earthing switch, ² as option

³ voltage transformers in the busbar are only possible in the left end panel

⁴ possible combinations:

- current transformer - earthing switch
- current transformer - voltage transformer
- voltage transformer - earthing switch

PRO-AIR H•e

The H•e version is available as a cable panel, transformer feeder panel, bus sectionalizer panel, riser panel, measuring panel and circuit breaker panel (semi-fixed type and in withdrawable unit design) up to I_k 20 kA resp. 31,5 kA. The PRO-AIR H•e-K weighs approximately 650 kg in the standard version.

PRO-AIR H•e		
• Rated voltage	U_r	36 kV
• Rated frequency	f_r	50 Hz
• Rated operating current, max.	I_r	2000 A
• Rated short-time current, max.	I_k	31,5 kA
• Rated short-circuit time	t_k	3 s
• Rated peak withstand current, max.	I_p	80 kA
• Rated lightning impulse withstand voltage	U_p	170 kV
• Rated power-frequency withstand voltage	U_d	70 kV

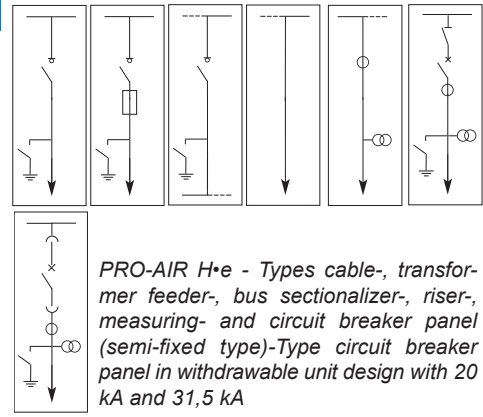

Switchgear design

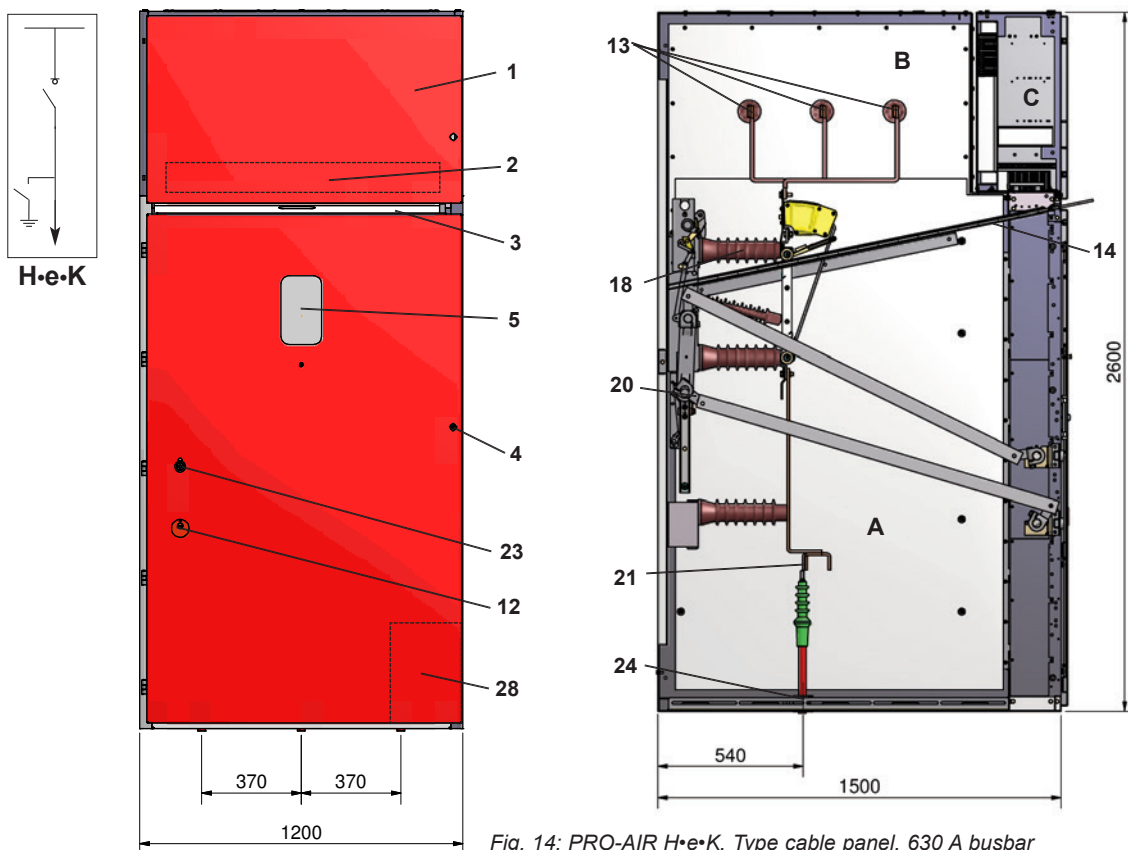

Fig. 14: PRO-AIR H•e-K, Type cable panel, 630 A busbar

- | | | |
|--|--|--|
| 1 Door or plate secondary cabinet | 13 Busbar | 28 Wiring cabinet ² |
| 2 Area for voltage detection system ² - Short-circuit indicator | 14 Insulating protective barrier | A Cable connection- and switch-gear area |
| 3 Opening for insulating protective barrier | 18 Switch-disconnector H22 | B Busbar area |
| 4 Door central lock | 20 Earthing switch | C Secondary cabinet ¹ |
| 5 Inspection window | 21 Cable connection | |
| 12 Operation and Position indication ES ¹ | 23 Operation and Position indication SD ¹ | |
| | 24 Crossbar, adjustable | |

¹ SD=Switch-disconnector H22, ES=Earthing switch, ² as option

Switchgear design

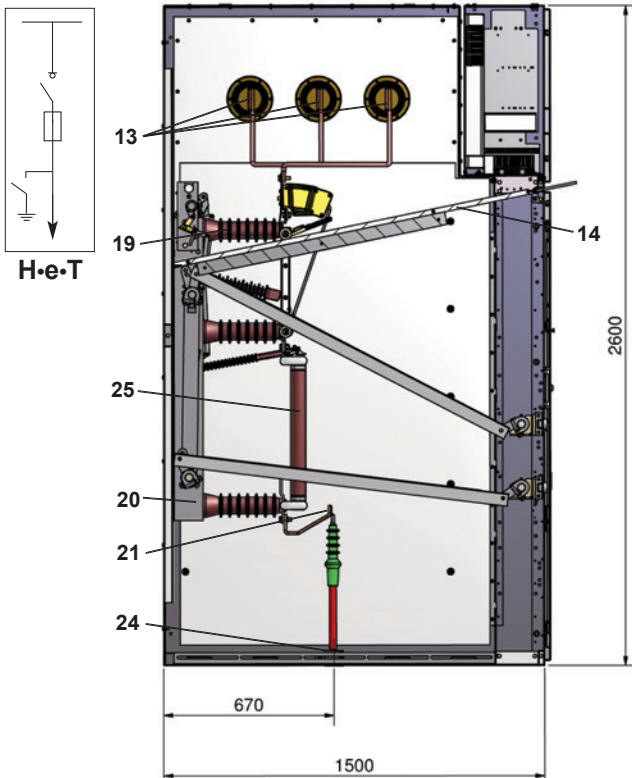

Fig. 15: PRO-AIR H•e•T, Type transformer feeder panel, 1250 A busbar

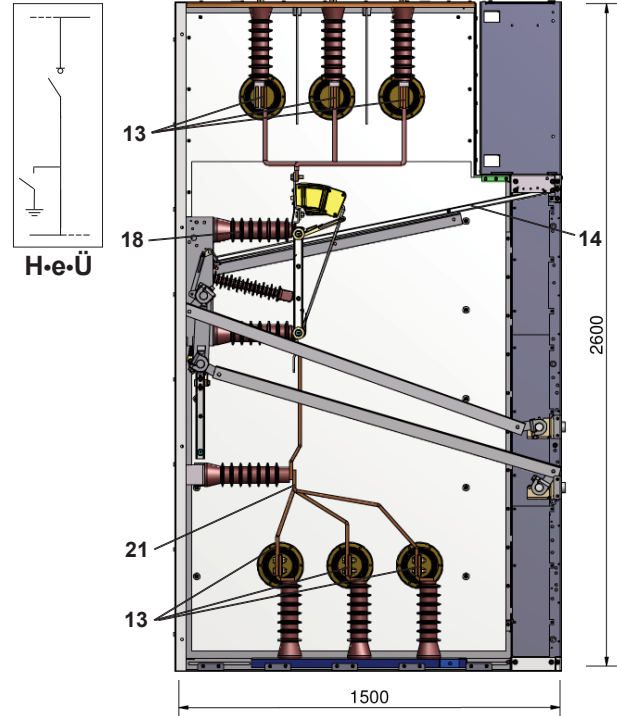

Fig. 16: PRO-AIR H•e•Ü, Type bus sectionalizer panel, 630 A busbar

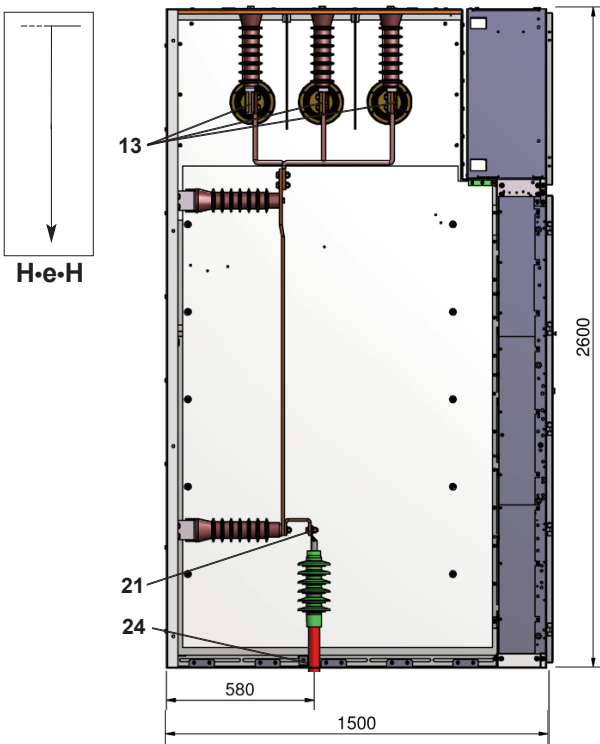

Fig. 17: PRO-AIR H•e•H, Type riser panel, 630 A busbar

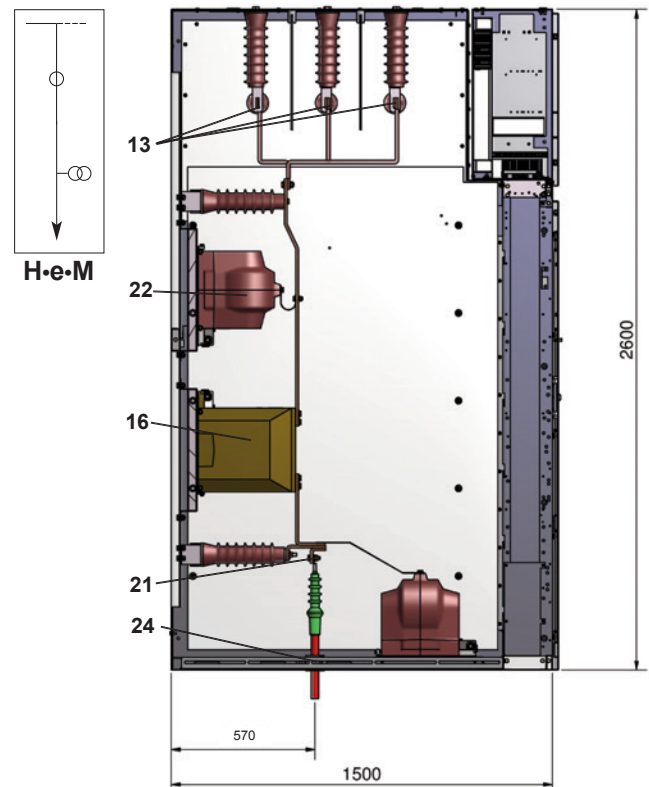

Fig. 18: PRO-AIR H•e•M, Type measuring panel, 630 A busbar

- 13 Busbar 14 Insulating protective barrier 16 Current transformer 18 Switch-disconnector H22 19 Switch-fuse combination H22
- 20 Earthing switch 21 Cable connection 22 Voltage transformer 24 Crossbar, adjustable 25 H.v.h.b.c fuses

Switchgear design

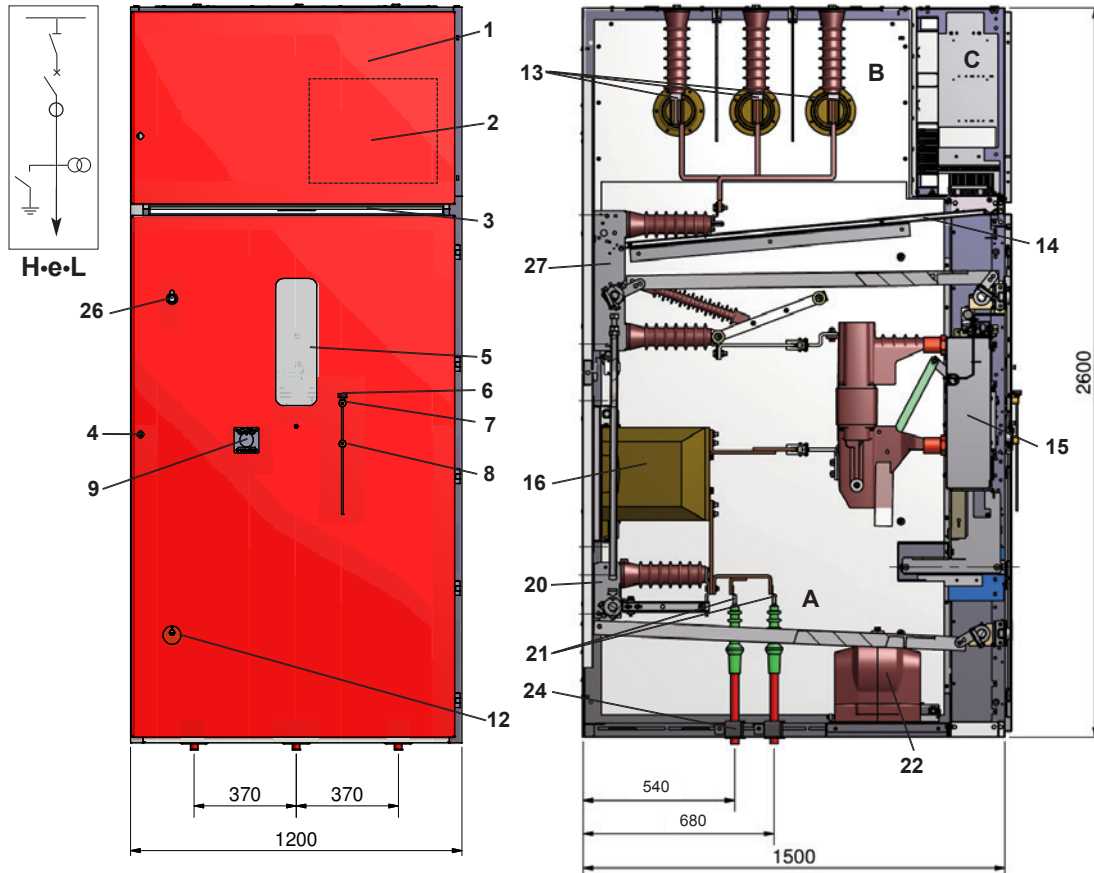

Fig. 19: PRO-AIR H•e•L, Type circuit breaker panel 20 kA (semi-fixed type), 1250 A busbar

- | | | |
|--|--|--|
| 1 Door secondary cabinet | 9 Hand-wound mechanism VCB ¹ | 24 Crossbar, adjustable |
| 2 Area for Protective relay ² , Operation-elements ² , Voltage detection system ² | 12 Operation and Position indication ES ¹ | 26 Operation and Position indication DI ¹ |
| 3 Opening for insulating protective barrier | 13 Busbar | 27 Disconnecter |
| 4 Door central lock | 14 Insulating protective barrier | 30 Service truck ² |
| 5 Inspection window for indication VCB ¹ | 15 Vacuum circuit breaker | |
| 6 Manual operation stick VCB ¹ | 16 Current transformer | A Cable connection- and switch-gear area |
| 7 Manual operation VCB ¹ ON | 20 Earthing switch | B Busbar area |
| 8 Manual operation VCB ¹ OFF | 21 Cable connection | C Secondary cabinet |
| | 22 Voltage transformer | |

¹ VCB=Vacuum circuit breaker, ES=Earthing switch, DI=Disconnecter ² as option

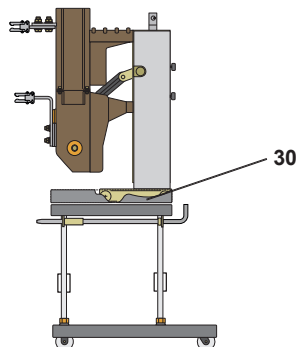

Fig. 20: Service truck

PRO-AIR H•e•EL, 20 kA

The type H•e•EL (circuit breaker panel in withdrawable unit design) is available with rated short-time current I_k 20 kA. The Type PRO-AIR H•e•EL (20 kA) weighs approximately 850 kg in the standard version.

Switchgear design

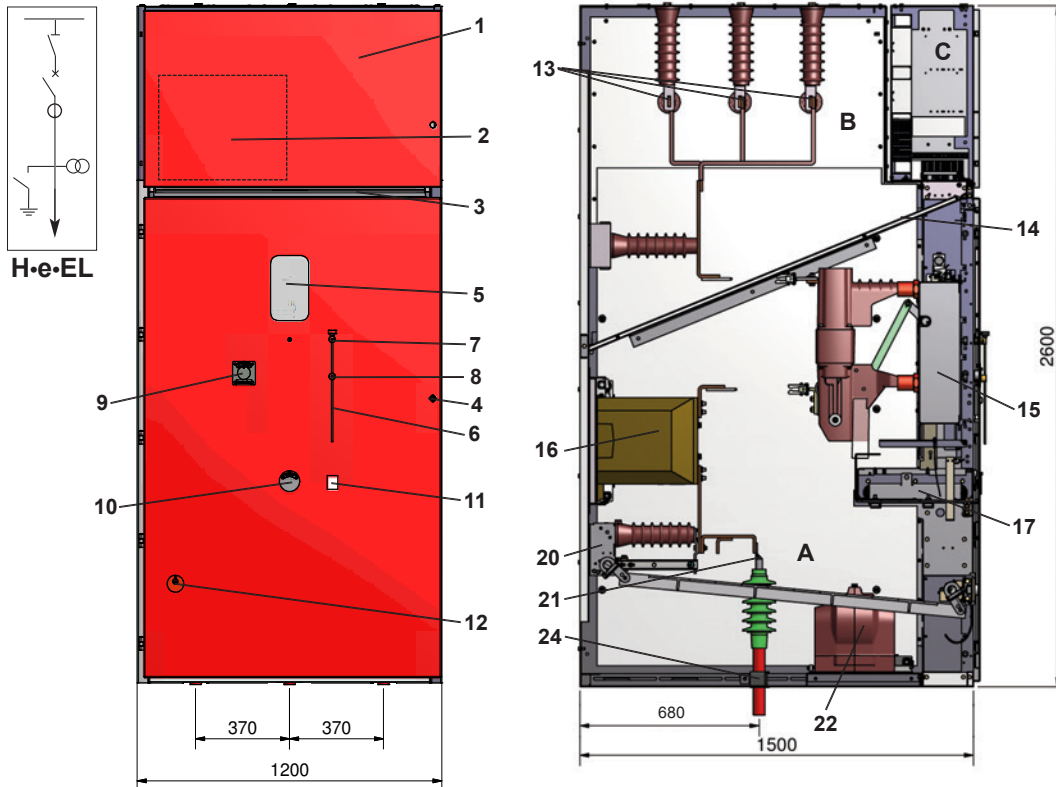

Fig. 21: PRO-AIR H•e•EL, Type Circuit breaker in withdrawable unit design 20 kA, 630 A busbar

- | | | |
|--|--|--|
| 1 Door secondary cabinet | 10 Operation for WC ¹ | 21 Cable connection |
| 2 Area for Protective relay ² , Operation-elements ² , Voltage detection system ² | 11 Position indication for WC ¹ | 22 Voltage transformer |
| 3 Opening for insulating protective barrier | 12 Operation and Position indication ES ¹ | 24 Crossbar, adjustable |
| 4 Door central lock | 13 Busbar | 30 Service truck, service fork lift ² |
| 5 Inspection window for indication VCB ¹ | 14 Insulating protective barrier | A Cable connection- and switch-gear area |
| 6 Manual operation stick VCB ¹ | 15 Vacuum circuit breaker | B Busbar area |
| 7 Manual operation VCB ¹ ON | 16 Current transformer | C Secondary cabinet |
| 8 Manual operation VCB ¹ OFF | 17 Withdrawable cassette for VCB ¹ | |
| 9 Hand-wound mechanism VCB ¹ | 20 Earthing switch | |

¹ VCB=Vacuum circuit breaker, ES=Earthing switch, WC=Withdrawable cassette ² as option

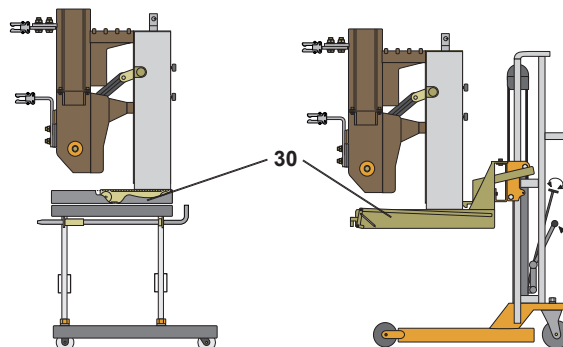

Fig. 22: Left side :Service truck, right side: Service fork lift

PRO-AIR H•e•EL, 31,5 kA

The type H•e•EL (circuit breaker panel in withdrawable unit design) is available with rated short-time current I_k 31,5 kA. The Type PRO-AIR H•e•EL (31,5 kA) weighs approximately 1100 kg in the standard version.

Switchgear design

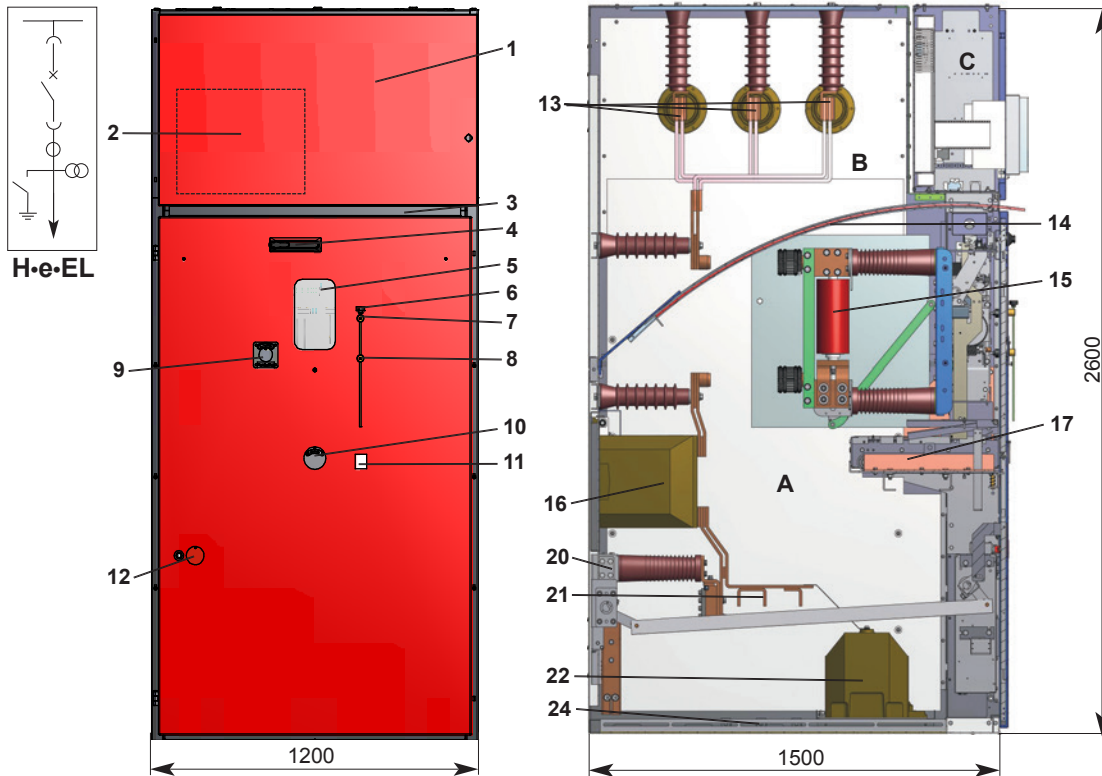

Fig. 23: PRO-AIR H•e•EL, Type circuit breaker in withdrawable unit design 31,5 kA, 2000 A busbar

- | | | |
|--|--|---|
| 1 Door secondary cabinet | 10 Operation for WC ¹ | 21 Cable connection |
| 2 Area for Protective relay ² , Operation-elements ² , Voltage detection system ² | 11 Position indication for WC ¹ | 22 Voltage transformer |
| 3 Opening for insulating protective barrier | 12 Operation and Position indication ES ¹ | 24 Crossbar, adjustable |
| 4 Door central lock | 13 Busbar | 30 Service truck ² |
| 5 Inspection window for indication VCB ¹ | 14 Insulating protective barrier | A Cable connection- and switchgear area |
| 6 Manual operation stick VCB ¹ | 15 Vacuum circuit breaker | B Busbar area |
| 7 Manual operation VCB ¹ ON | 16 Current transformer | C Secondary cabinet |
| 8 Manual operation VCB ¹ OFF | 17 Withdrawable cassette for VCB ¹ | |
| 9 Hand-wound mechanism VCB ¹ | 20 Earthing switch | |

¹ VCB=Vacuum circuit breaker, ES=Earthing switch, WC=Withdrawable cassette ² as option

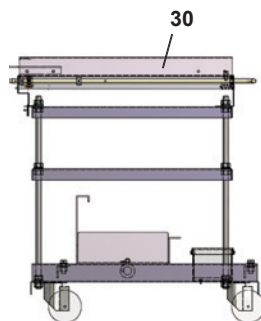

Fig. 24: Service truck

STROM • SICHER • SCHALTEN

Dimensions, weights, diagrams and descriptions in this brochure are non-binding. Subject to change without notice.

Printed on chlorine free bleached paper. For nature's sake.



**Elektrotechnische Werke
Fritz Driescher & Söhne GmbH**

Driescherstr. 3
D-85368 Moosburg
Germany
Tel.: +49 8761 681-0
Fax: +49 8761 681-137
E-Mail: infoservice@driescher.de

DRIESCHER GmbH Eisleben

Hallesche Str. 94
D-06295 Lutherstadt Eisleben
Germany
Tel.: +49 3475 7255-0
Fax: +49 3475 6966-99
E-Mail: infoservice@driescher-eisleben.de
www.driescher.de

DRIESCHER
Moosburg • Eisleben

